

Excerpt Chapter from Patton, A.J. 2008. Practical math for the turfgrass professional. University of Arkansas Cooperative Extension Service. CDHORT-200.

Contact Aaron Patton (ajpatton@uark.edu) for a full electronic copy of this publication.

Section

8

Calibration

Calibrating is the first and most important step to product application

Calibrating is often a dreaded task that is usually skipped or performed seldom by many turfgrass managers. Apathy toward calibration can lead to over or under application of pesticides and fertilizers which will injure turf, waste money, and potentially harm the environment. Miscalibration is the number one reason for pesticide performance failure. Calibration is not as difficult as it may initially seem. Worksheets contained in this section will aid managers in calibrating their equipment regardless of the application method.

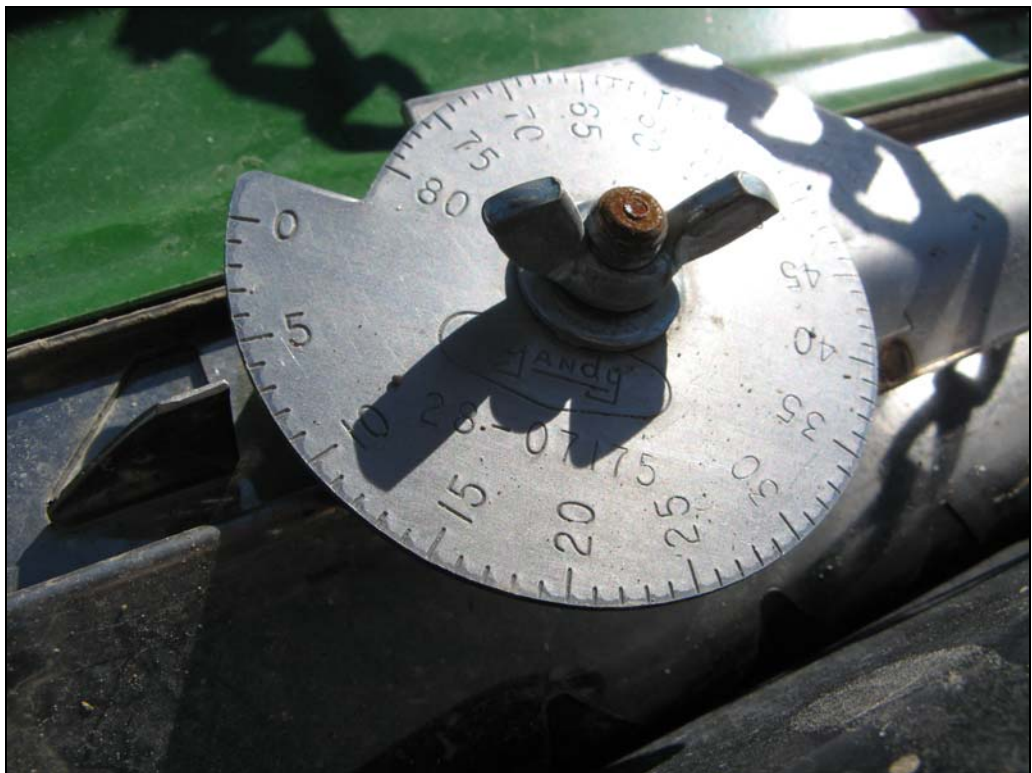

Figure 8.1 Proper calibration is essential for proper pesticide and fertilizer application.

Calibration of a Boom Sprayer

Adapted from Reicher, Z.J. and C. Throssell, Sprayer and Spreader Calibration

Calibration is essential to ensure that the desired amount of a pesticide or fertilizer is applied to the turfgrass site. Improper calibration may cause poor pest control, environmental contamination, injury to the desired turf, and unnecessary expenditures for pesticides.

Improperly calibrated sprayers are common on golf courses. A study conducted by Varner et al. (1990) showed that only 17% of the sprayers used on golf courses in Nebraska applied within 5% of the intended amount.

A sprayer should be calibrated at the start of every growing season and the calibration should be checked at least once a month during the growing season. Nozzles should be checked for wear each time the sprayer is calibrated, and all screens should be cleaned each time the sprayer is used.

Steps to Calibrating a Boom Sprayer

- Step 1** Measure a calibration course 100 feet in length over terrain that is similar to terrain where the sprayer will be operating so that the load on the engine will reflect actual conditions.
- Step 2** Determine the amount of time required to cover the 100 foot calibration course when operating the sprayer at the desired spraying speed. Be sure the sprayer is at the desired spraying speed when passing the start and end points of the calibration course. It is best to make two passes over the calibration course in opposite directions and use the average time for calibration calculations. The spray tank should be half full when making the calibration runs. Be sure to record the gear, rpm or mph, and pressure at which the calibration runs were made (whichever is appropriate to the machine). If calibrating your walking speed for application with a lawn care gun, use a shorter distance course since some hoses may be shorter than 100 feet.
- Step 3** Pavement test the sprayer using water for proper nozzle adjustment and to determine the effective spray width. First, clean all nozzle screens and inspect each nozzle. Next, fill the sprayer with water and spray at the desired speed. Observe the wet pavement as it dries. Adjust the nozzles until the coverage is uniform across the spray width. Lastly, operate the sprayer again while spraying. Mark the edges of the effectively covered area and measure to determine the effective spray width. This should be equal to the width of the boom and/or the same as the number of nozzles multiplied by the distance in feet between nozzles. Now, it is possible to calculate the area of the calibration run. (100 feet × effective spray width).
- Step 4** Measure the nozzle output of the sprayer by placing a collection vessel under each nozzle and operating the sprayer for the same duration it took to cover the calibration course (Step 2) while at the same rpm. Record the output in

ounces (oz) or milliliters (mL) of each nozzle and add to determine the output of all nozzles for the sprayer. Replace the nozzle and repeat step 4 if an individual nozzle is 10% higher or lower than the average nozzle output.

Step 5 Calculate the number of gallons output per ft² of calibration course.
(1 gal = 3785 mL; 1 gal = 128 oz)

Step 6 Convert from gallons/ft² to gallons per 1,000 ft² or to gallons per acre.
(43,560 sq. ft. = 1 acre)

Boom Sprayer Calibration Worksheet

A. Amount of time needed to travel the calibration course.

	Direction A	Direction B	Average
Seconds to travel 100 ft.			

Notes:

(Gear: _____ RPM & MPH: _____ Pressure _____ Nozzle type: _____)

B. Width of boom _____ feet. NOTE: this the effective spray width.
Width of boom (ft) = Spacing between nozzles (ft) x number of nozzles
Width of boom (ft) = _____ (ft) x _____

Width of boom (ft) = _____ (ft)

C. Calculate the number of square feet covered in the calibration course.
100 ft. (from A) × _____ ft. boom width (from B) = _____ sq. ft. covered

_____ seconds to travel the calibration course. Average of two directions.

D. Measure the sprayer output for the same number of seconds it took to complete the calibration course. (Collect data as either ml or oz.) Convert from ml to oz. by dividing by 29.57.

Nozzle # 1	_____ ml	_____ oz
2	_____ ml	_____ oz
3	_____ ml	_____ oz
4	_____ ml	_____ oz
5	_____ ml	_____ oz
6	_____ ml	_____ oz
7	_____ ml	_____ oz
8	_____ ml	_____ oz
9	_____ ml	_____ oz
10	_____ ml	_____ oz
11	_____ ml	_____ oz
12	_____ ml	_____ oz
Total	_____ ml	_____ oz

In summary:

Total _____ ml collected in _____ seconds or per _____ sq. ft. (from C)

Total _____ oz collected in _____ seconds or per _____ sq. ft. (from C)

E. Calculate the output per sq. ft. of the calibration course.

Total output in ml _____ (from D) \div 3785 \div sq. ft. covered _____ (from C)

= _____ (gallons per square foot covered).

or

Total output in oz _____ (from D) \div 128 \div sq. ft. covered _____ (from C)

= _____ (gallons per square foot covered).

F. Convert gallons per number of square feet of the calibration course to gals. per 1,000 sq. ft. or gallons per acre.

Gallons per 1,000 ft²

= _____ (gal/sq. ft., from part E) \times 1000

= _____ (gallons per 1,000 ft²)

Gallons per Acre

= _____ (gal/sq. ft., from part E) \times 43,560

= _____ (gallons per Acre)

Checking for Worn Nozzle Tips

Step 1 Measure the output of each nozzle in comparison to one new nozzle placed in the boom. Output can be measured by a collection vessel placed under each nozzle and operating the sprayer for one minute.

Step 2 Record the output from each nozzle. If the output from any nozzle is 10% or greater than the output from the new nozzle the old nozzle should be replaced. If two or more nozzles have an output 10% or greater than the new nozzle, all nozzles on the boom should be replaced. It is important to have uniform output from all nozzles.

Calculating Flow Rate

Certain pesticides may be more effective at lower or higher spray volumes (i.e. gallons per acre). One method to modify your spray volume is by first calculating your flow rate and then selecting a nozzle for its flow rate at a certain sprayer pressure. The first step in determining flow rate is to calculate your sprayer's travel speed in miles per hour (MPH).

M P H

General formula

$$= \frac{\text{Distance in feet} \times 60}{\text{Time in seconds} \times 88}$$

Example 1. Calculate the MPH for a sprayer traveling 100 feet in 17.05 seconds.

$$= \frac{100 \times 60}{17.05 \times 88}$$
$$= 4 \text{ miles per hour (MPH)}$$

F L O W R A T E :

General formula

$$= \frac{\text{Gallons per acre (GPA)} \times \text{MPH} \times \text{nozzle spacing (inches)}}{5940}$$

Example 2. Calculate the flow rate in gallons per minute for a sprayer calibrated at 44.8 gallons per acre with a 14 inch nozzle spacing and traveling 4 MPH.

$$= \frac{44.8 \times 4 \times 14}{5940}$$
$$= 0.42 \text{ gallons per minute}$$

Sprayer Calibration Problems

Regardless of method there are two main steps:

1. Determine amount of water per time
2. Determine the amount of time per area

When measuring traveling speed as mph

General formula

Collection (mL)	Number of nozzles		1 gallon		1 mile		43560 ft ²	60 min	60 sec
1 nozzle		Collection time	3785 mL	MPH	5280 ft	boom width (ft)	acre	1 hour	1 min

Example 3. How many gallons per acre would be applied using the following sprayer?

- 12 nozzles
- Each nozzle releases 800 mL in 30 seconds
- 14 foot wide boom
- The sprayer is traveling at 4 mph

800 mL	12 nozzles		1 gallon	1 hour	1 mile		43560 ft ²	60 min	60 sec
1 nozzle		30 sec	3785 mL	4 miles	5280 ft	14 ft boom	1 acre	1 hour	1 min

This should be computed as $800 \text{ mL} \times 12 \text{ nozzles} \times 1 \text{ gallon} \times 1 \text{ hour} \times 43,560 \text{ ft}^2 \times 60 \text{ min} \times 60 \text{ sec} \div 1 \text{ nozzle} \div 30 \text{ sec} \div 3,785 \text{ mL} \div 4 \text{ miles} \div 5280 \text{ ft} \div 14 \text{ ft} \div 1 \text{ acre} \div 1 \text{ hour} \div 1 \text{ min} =$ _____

= 44.8 gallons per acre

SHORTCUT:

General formula

$$= \frac{\text{Gallons per minute (GPM) per nozzle} \times 5940}{\text{MPH} \times \text{nozzle spacing or sprayed width (inches)}}$$

Example 4. How many gallons per acre would be applied using the following sprayer?

$$= \frac{(800 \times 2 / 3785) \times 5940}{4 \times 14}$$

= 44.8 gallons per acre

When measuring traveling speed as time / distance

General formula

Collection (mL)	Number of nozzles		1 gallon	time		43560 ft ²
1 nozzle		Collection time	3785 mL	Distance traveled	boom width (ft)	1 acre

Example 5. A sprayer has a 14 ft boom and 12 nozzles. Each nozzle releases 775 ml of spray in 20 seconds. A 200 ft test strip is established and the sprayer is timed to travel the distance in 45 seconds. How many gallons per acre are being applied?

800 mL	12 nozzles		1 gallon	34.1 sec.		43560 ft ²
nozzle		30 sec.	3785 mL	200 ft	14 ft boom	1 acre

This should be computed as 800 mL × 12 nozzles × 1 gallon × 34.1 sec × 43,560 ft² ÷ 1 nozzle ÷ 30 sec ÷ 3,785 mL ÷ 200 ft ÷ 14 ft ÷ 1 acre = _____

= 44.8 gallons per acre

Calibrating a Lawn Gun

Calibrating a lawn care gun is difficult because every applicator will walk at slightly different speeds as well as using slightly different spray techniques. Therefore it is important to calibrate each individual with each gun. A lawn gun delivers the majority of the material directly in front of the applicator as he/she walks and sprays with a rapid side-to-side shoulder/arm motion. Therefore, less material is applied on the applicator's right or left compared to directly in front of the applicator. Therefore, lawn guns require 100% overlap on subsequent passes (50% overlap on right and 50% overlap on left) to ensure uniform application. When determining the effective spray width while calibrating the lawn gun the effective spray width should be calculated as one-half of the area covered in one pass. In other words if a 10 foot width of spray is applied in one pass, then the effective spray width would be 5 feet. Use the following worksheet to calibrate a lawn gun.

Individual 1: Test 1

- Step 1 Lay out a rectangular area 50 ft long by 20 ft wide (1000 ft²).
- Step 2 Record the amount of time it takes for an applicator to uniformly apply water to this area.
_____ seconds
- Step 3 Spray into a five gallon bucket for the amount of time recorded in Step 2. Measure the amount of water collected in the bucket in fluid ounces.
_____ oz
- Step 4 Divide the water collected in step 3 by 128 (1 gallon = 128 fluid ounces) to calculate spray volume in gallons/1000 ft².
_____ oz ÷ 128 oz/gallon = _____gallon/1000 ft²
- Step 5 Divide the gallonage in the spray tank by the answer in Step 4 to calculate the area that can be covered with one tankful.
_____ gallons in spray tank ÷ _____gallons/1000 ft² = _____ft²/tank

Individual 1: Test 2

- Step 1 Lay out a rectangular area 50 ft long by 20 ft wide (1000 ft²).
- Step 2 Record the amount of time it takes for an applicator to uniformly apply water to this area.
_____ seconds
- Step 3 Spray into a five gallon bucket for the amount of time recorded in Step 2. Measure the amount of water collected in the bucket in fluid ounces.
_____ oz
- Step 4 Divide the water collected in step 3 by 128 (1 gallon = 128 fluid ounces) to calculate spray volume in gallons/1000 ft².
_____ oz ÷ 128 oz/gallon = _____gallon/1000 ft²
- Step 5 Divide the gallonage in the spray tank by the answer in Step 4 to calculate the area that can be covered with one tankful.
_____ gallons in spray tank ÷ _____gallons/1000 ft² = _____ft²/tank

Calibrating Ride-on Spreader/Sprayers

The use of ride-on sprayer/spreaders has increased recently (Fig. 8.2). Ride-on sprayers/spreaders increase work efficiency by allowing areas to be fertilized and sprayed more quickly while preserving employee energy. Additionally, ride-on sprayer spreaders allow the combining of two separate pieces of equipment into one for added convenience. Since this type of equipment is new to the turfgrass industry, there are many who do not have experience calibrating ride-on spreaders/sprayers. Specific procedures for calibrating the sprayer and spreader functions of ride-on equipment are included here.

A sprayer should be calibrated at the start of every growing season and the calibration should be checked at least once a month during the growing season. Nozzles should be checked for wear each time the sprayer is calibrated. All screens should be cleaned each time the sprayer is used. There are two main types of ride-on spreader/sprayers. Those with a boom-type sprayer and those with a single-nozzle applicator (Fig. 8.2). Specific procedures for calibrating both are included in this publication.

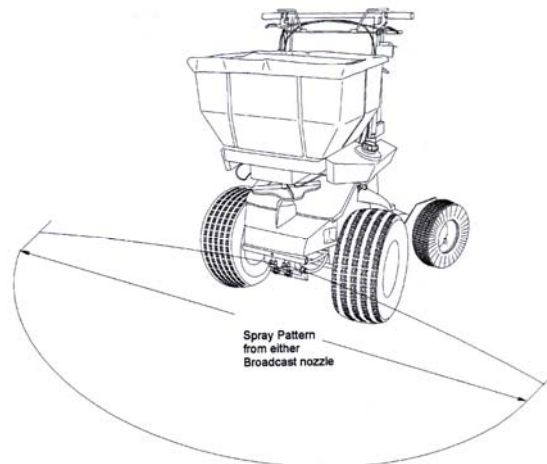

Figure 8.2. Single nozzle applicator broadcast pattern.

Steps to Calibrating a Spreader/Sprayer (any type)

(example: PermaGreen or Z-Spray)

- Step 1** Measure a calibration course 100 feet in length over terrain that is similar to terrain where the sprayer will be operating so that the load on the engine will reflect actual conditions.
- Step 2** Determine the amount of time required to cover the 100 foot calibration course when operating the sprayer at the desired spraying speed. Be sure the sprayer is at the desired spraying speed when passing the start and end points of the calibration course. It is best to make two separate passes over the calibration course in opposite directions and use the average time for calibration calculations. The spray tank should be half full when making the calibration runs. Be sure to record the gear, rpm, and pressure at which the calibration runs were made (whichever is appropriate to the machine).
- Step 3** Pavement test the sprayer using water for proper nozzle adjustment and to determine the effective spray width. First, clean the nozzle screen and inspect the nozzle(s). Next, fill the sprayer with water and spray at the desired speed. Observe the wet pavement as it dries. Adjust the nozzle(s) until the coverage is uniform across the spray width. Next, operate the sprayer again while spraying. Mark the edges of the effectively sprayed area and measure to determine the effective spray width.
- Step 4** Measure the nozzle output of the sprayer by placing a collection vessel under one nozzle and operating the sprayer for one minute while at the same rpm. Record the output of one nozzle to determine the approximate output of the sprayer.
- Step 5** Calculate gallons per acre with the formula in the calibration worksheet below.

Spreader/Sprayer Calibration Worksheet (any type)

- A.** Calculating Sprayer speed in miles per hour (MPH). First record the time needed to travel 100 feet (or shorter for lawn guns).

Direction A Direction B Average time (s)
 _____ _____ _____

Seconds to travel 100 feet (or shorter for lawn guns). Answer = _____.

(Gear: _____ RPM: _____ Pressure: _____ Nozzles: _____)

MPH

distance traveled	60
average time (seconds)	88

This should be computed as distance traveled \times 60 \div average time (sec.) \div 88 = Answer = _____ MPH

- B.** Single nozzle applicator effective spray width = _____ feet. Convert to inches by multiplying by 12 = _____ inches.

Nozzle spacing _____ (inches) on boom type sprayers.

- C.** Measure the sprayer output for one nozzle for one minute (record values in gallons, milliliters, or ounces).

Nozzle 1 _____ gallons _____ mL _____ oz

If recorded as mL divide by 3,785 to get gallons per minute. Answer = _____

If recorded as oz divide by 128 to get gallons per minute. Answer = _____

- D.** Calculate gallons per acre with formula below.

GPA equation

$$\frac{5,940 \times \text{GPM (per nozzle)}}{\text{MPH} \times \text{W (inches)}} \quad \text{or} \quad \frac{5,940 \times \text{GPM (per nozzle)}}{\text{MPH} \times \text{W (inches)}}$$

W = nozzle spacing in inches (or effective spray width for single nozzle applicator)(from part B)

GPM = gallons per minute (from part C)

GPA = gallons per acre

MPH = miles per hour (from part A)

This should be computed as $5,940 \times \text{gallons per minute (C)} \div \text{MPH} \div \text{W} = \text{Answer} =$
_____ gallons/acre (GPA)

NOTE: Gallons per 1000 ft² can be calculated by dividing by 43.56. This should be computed
as gallons/acre (D) $\div 43.56 = \text{Answer} =$ _____ gallons/1000 ft²

Sprayer coverage

Once you have determined the sprayer output in gallons per acre you can determine the amount of turf you will be able to spray per tank. This can also be converted to 1000 ft²/tank.

Divide the size (gallons) of the spray tank by the GPA to calculate the acres that can be covered with one tank.

_____ gallons in spray tank \div _____ gallons/acre = _____ acres/tank

_____ acres/tank $\times 43,560 =$ _____ ft²/tank

Calibrating a Hand Sprayer

To calibrate a backpack sprayer you must first figure how many square feet the filled sprayer will cover. This will vary from person to person because people walk at different speeds.

Steps to Calibrating a Hand Sprayer

Step 1 Fill the sprayer with about 1 gallon of water and pump it up.

Step 2 Holding your arm extended, as you would when spraying, spray water onto dry pavement while standing still. Measure and record the width of the spray line.

Step 3 Walk in a straight line, while spraying, for 15 seconds at the pace you would use when spraying. Measure the distance you walked in 15 seconds.

Step 4 Multiply the width of the spray pattern by the distance covered in 15 seconds to determine the area sprayed in 15 seconds.

Step 5 Spray for 15 seconds into an empty container. Measure the amount of water collected in the container in fluid ounces.

Step 6 Multiply the area sprayed that was calculated in Step 4 by the capacity of the sprayer in fluid ounces (1 gallon = 128 fluid ounces). Divide the resulting quantity by the number of fluid ounces collected in 15 seconds of spraying. The result is the amount of square feet that can be covered with a full tank of spray solution.

Calibrating a Hand Sprayer

- A. Width of spray pattern: _____ ft.
- B. Distance covered during 15 seconds of spraying: _____ ft.
- C. Area covered in 15 seconds of spraying:
width _____ ft. x distance _____ ft. = _____ square feet
- D. Fluid ounces collected in 15 seconds: _____ fl. oz.
- E. Capacity of the sprayer: _____ (gallons)
- F. Capacity of the sprayer in fluid ounces. Since there are 128 fluid ounces per gallon, then 128 multiplied by the number of gallons in one tank will give us the capacity in fluid ounces.

$$(E) \times (128) = \underline{\hspace{2cm}} \text{ fluid ounces}$$

G. Calculate the area that can be sprayed by a full tank of spray solution.

Area covered in 15 seconds of spraying \times capacity of the sprayer in fluid ounces \div fluid ounces collected in 15 seconds = the area than can be sprayer by a full tank of spray solution

$(C) \times (F) \div (D) =$ the area than can be sprayer by a full tank of spray solution

$\underline{\hspace{1cm}} \times \underline{\hspace{1cm}} \div \underline{\hspace{1cm}} = \underline{\hspace{2cm}}$ square feet covered by a full tank of spray solution

Rotary Spreader Calibration

A properly maintained and calibrated spreader is an essential piece of equipment for all professional turfgrass managers. Fertilizers and pesticides are formulated for application at a specific recommended rate. Over application of a fertilizer or pesticide is an unnecessary expense that may injure turf and potentially harm the environment. Under application may be more costly because of poor turf response and the need to re-treat sooner because of poor product performance.

A fertilizer spreader should be calibrated at least once a week if it is used frequently or once a month if used infrequently. The spreader must be calibrated for each material to be used and for each speed (gear) at which it is used.

Before calibrating a spreader, it should be thoroughly checked to be sure it is in proper working condition. Items to check include:

- tires properly inflated
- axels greased and tires turn freely
- spreader hopper and impeller clean
- screen inside the hopper
- agitation bar inside the hopper
- adjustment knob will hold its position
- rain cap present
- gears greased (if recommended) and all teeth on gears present
- pattern adjustment set

Calibration of a rotary spreader includes three aspects: uniform distribution across the pattern, effective pattern width, and the rate of application.

Uniform Distribution Across the Pattern

The purpose of this procedure is to ensure that equal amounts of the material are being thrown to the right and left of the spreader.

Step 1 Place shallow boxes or pans side by side in a line perpendicular to the direction the spreader will be pushed. One box should be placed directly beneath the spot where the spreader will pass, leaving space for the spreader wheels to pass on either side of the box. Below is a diagram showing placement of the boxes.

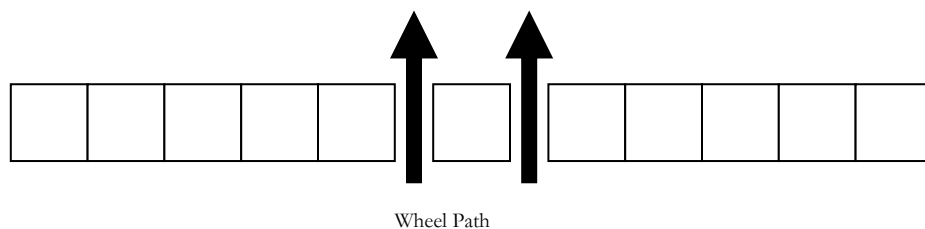

Figure 8.3. Diagram of collection box layout for determining a rotary spreader's distribution pattern.

Step 2 Set the spreader at the opening that is suggested for the material.

Step 3 Set the pattern adjustment so it is completely open. The diagram below indicates the location of the pattern adjustment for two types of spreaders.

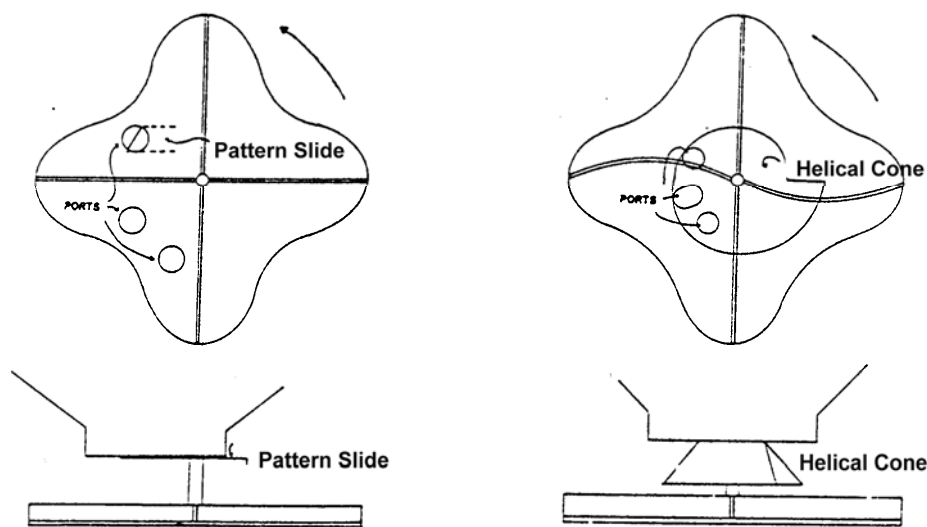

Figure 8.4. Pattern slides and helical cones are used to adjust product distribution on rotary spreaders.

Step 4 Fill the spreader half full and make 8 to 10 passes over the boxes pushing the spreader in the same direction each time. This is best done over a clean garage floor. Be sure the spreader impeller is parallel to the ground and a constant walking speed is used for each pass. Full walking speed should be achieved before turning on the spreader.

Step 5 The contents of each box should be weighed separately or poured into a small bottle. The bottles should then be placed side by side in order. This will allow you to see the spreader pattern variation. The diagram below illustrates possible spreader patterns.

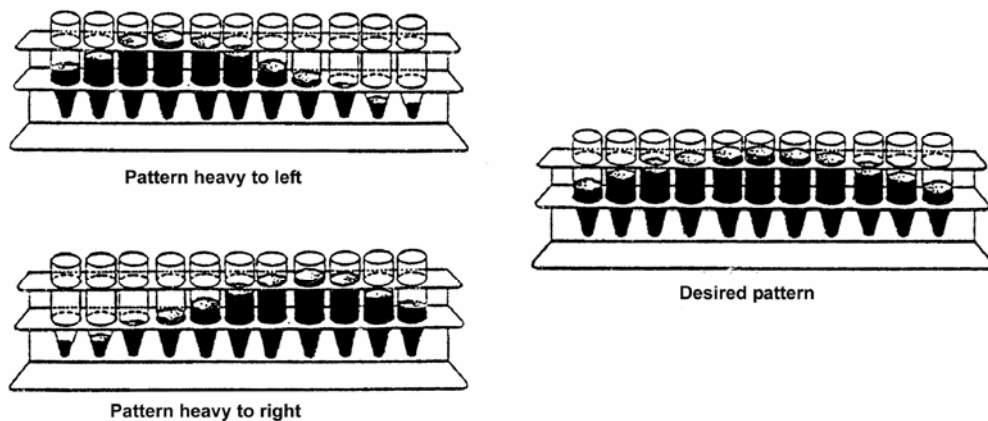

Figure 8.5. Sample pattern distributions from various helical cone or pattern slide settings.

Step 6 Weigh the material collected in the boxes on the right and then weigh the material collected in the boxes on the left. The weight of material collected on each side should be within 15% of each other. If not, change the pattern adjustment setting.

Step 7 Repeat the test until the distribution pattern is uniform.

Determine the Effective Pattern Width

When a uniform pattern is achieved, the effective pattern width can then be determined.

Step 1 Read the volumetric measurements on the side of the vials. Determine at what distance from the center of the pattern the distribution rate decreases to one half the amount contained in the center vial.

Step 2 The effective pattern width is the distance between the tray on the left and the tray on the right at which the distribution rate is one-half the amount contained by the tray in the center. Measure this distance.

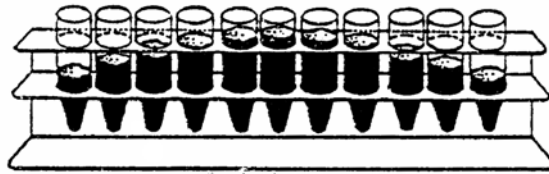

Figure 8.6. Uniform pattern distribution indicating proper helical cone or pattern slide adjustment.

Step 3 This distance is the effective pattern width and is the distance between spreader passes necessary to obtain uniform distribution.

Rate of Application

Step 1 The effective swath width and distribution pattern must be known for the material.

Step 2 Measure a line to equal 1,000 sq. ft.

$$\text{Line distance} = \frac{1,000 \text{ sq. ft.}}{\text{effective swath width (ft.)}}$$

Step 3 Calculate the required weight of fertilizer per 1,000ft² needed to apply the desired amount of nitrogen. Example: If you want to apply 1.0 lbs. actual nitrogen per 1,000ft² using urea (46-0-0) you should apply 2.17 lbs. of urea per 1,000 ft².

General formula

Rate	1 lb fertilizer	Area to be treated
1,000 ft ²	Analysis	

Example 1. How much 46-0-0 is needed to apply 1.0 lbs N/1000ft² to a 5,000 ft² lawn?

1.0 lbs N	1 lb fertilizer	1,000 ft ²
1,000 ft ²	0.46 lbs N	

This should be computed as 1.0 lbs N × 1 lb fertilizer × 1,000 ft² ÷ 1,000 ft² ÷ 0.46 lbs N =

Answer = 2.17 lbs 46-0-0 fertilizer

Step 4 Weigh 20 lbs. of the product and place it in the spreader hopper and spread it over the distance required to equal 1,000ft². Two or more passes will improve accuracy of the calibration. If you make two or more passes with the spreader be certain to make the appropriate adjustments for the extra square feet covered.

Step 5 Weigh the product remaining in the hopper and subtract this amount from the amount with which you started.

Step 6 The result is the application rate for this product in lbs. per 1,000ft². Adjust the spreader opening either up or down to achieve the desired setting.

Step 7 Repeat steps 4 through 6 until the correct application rate is achieved.

Rate of Application Calibration Worksheet

General formula

desired amount of actual nitrogen	1 lb fertilizer	1,000 ft ²
1,000 ft ²	nitrogen content of fertilizer	

This should be computed as desired amount of actual nitrogen (lbs N) × 1 lb fertilizer × 1,000 ft² ÷ 1,000 ft² ÷ nitrogen content of fertilizer (lbs N) = pounds fertilizer needed per 1,000 ft².

Calibration run#1

desired amount of actual nitrogen	1 lb fertilizer	1,000 ft ²
1,000 ft ²	nitrogen content of fertilizer	

This should be computed as _____ × 1 lb fertilizer × 1,000 ft² ÷ 1,000 ft² ÷ _____ = _____.

Calibration Spreader setting _____
Run #1

_____ lbs. fertilizer - _____ lbs. fertilizer = _____ lbs. fertilizer
in spreader remaining in applied
initially spreader

Calibration run#2

desired amount of actual nitrogen	1 lb fertilizer	1,000 ft ²
1,000 ft ²	nitrogen content of fertilizer	

This should be computed as _____ × 1 lb fertilizer × 1,000 ft² ÷ 1,000 ft² ÷ _____ = _____.

Calibration Spreader setting _____
Run #2

_____ lbs. fertilizer - _____ lbs. fertilizer = _____ lbs. fertilizer
in spreader remaining in applied
initially spreader

Calibration run#3

desired amount of actual nitrogen	1 lb fertilizer	1,000 ft ²
1,000 ft ²	nitrogen content of fertilizer	

This should be computed as _____ × 1 lb fertilizer × 1,000 ft² ÷ 1,000 ft² ÷ _____ = _____.

Calibration Spreader setting _____
Run #3

_____ lbs. fertilizer - _____ lbs. fertilizer = _____ lbs. fertilizer
in spreader remaining in applied
initially spreader

Drop Spreader Calibration

Calibration of a drop spreader is more simple than for a rotary spreader. Drop spreaders have a fixed uniform distribution across the pattern, a fixed spread width. Therefore, only the rate of application requires calibration.

Step 1 Calculate the required weight of fertilizer, seed, or pesticide per 1,000ft² needed to apply the desired amount of product. Example: If you want to apply 1.0 lbs. actual nitrogen per 1,000ft² using urea (46-0-0) you should apply 2.17 lbs. of urea per 1,000 ft². NOTE: It is common to apply one-half the product in one direction and then to apply the second half in a perpendicular direction. If applying in two-directions, then calculate half of the required application rate.

General formula - fertilizer

Rate	1 lb fertilizer	Area to be treated
1,000 ft ²	Analysis	

General formula - seed

Seeding rate	1 lb seed	Area
1000 ft ²	PLS	

General formula – pesticide product

Rate	Area to be treated	or	Rate	Area to be treated
1,000 ft ²			acres	

General formula – pesticide dry active ingredient

Rate	1 lb	Area to be treated	or	Rate	1 lb	Area to be treated
1,000 ft ²	percent a.i.			acre	percent a.i.	

Step 2 Fill the drop spreader with the chosen product used in step 1.

Brand of Spreader: _____ Brand of Product: _____

Step 3 Lay out a calibration course. Record the total length of the course, the spreader width, and then calculate the area covered in the calibration course.

- A. Total length traveled: _____ (ft)
 - NOTE: Multiply the number of passes (i.e. down and back = 2 passes) by the length of one pass across the calibration course.

B. Spreader width: _____ (ft)

C. Area of calibration course: _____ (ft²)

- Calculate as $A \times B = C$.

Step 4 Calculate the amount of product that will be collected from the calibration course when calibrated correctly.

lbs product (from Step 1)	Area of calibration course (from Step 3) (ft ²)	454 g
1,000 ft ²		lbs

This should be computed as _____ \times _____ ft² \times 454 g \div 1,000 ft² \div _____
lbs = _____ grams.

or

lbs product (from Step 1)	Area of calibration course (from Step 3) (ft ²)	16 oz
1,000 ft ²		lbs

This should be computed as _____ \times _____ ft² \times 16 oz \div 1,000 ft² \div _____
lbs = _____ oz.

Step 5 Estimate the required setting to deliver the appropriate amount of product and adjust the spreader to that setting.

Step 6 Apply product to the calibration course and collect the fertilizer that has been released and weigh it. NOTE: this is best done by applying the product to a clean garage floor or plastic sheet or by using a specially constructed “catch tray”.

Step 7 Weigh the product (in ounces or grams) released and note the setting in the chart below.

Step 8 Repeat steps 6-7 until the spreader delivers the appropriate amount of product.

Problems (see page 103 for answers)

2 pints	=	1 quart	1 pound	=	454 g
4 quarts	=	1 gallon	1 yard	=	3 ft
1 gallon	=	128 ounces	1 mile	=	5,280 ft
1 gallon	=	3,785 ml	1 acre	=	43,560 ft ²
1 gallon	=	8 pounds	P ₂ O ₅	is	44% P
1 pound	=	16 ounces	K ₂ O	is	83% K
1 hectare (ha)	=	10,000 m ²	1 gallon	=	3.785 liters

46. A sprayer has a 14 ft boom and 10 nozzles. Each nozzle releases 775 ml of spray in 20 seconds. A 200 ft test strip is established and the sprayer is timed to travel the distance in 45 seconds. How many gallons per acre are being applied?

47. How many gallons per acre would be applied using the following sprayer?

- 12 nozzles
- Each nozzle releases 700 mL in 25 seconds
- 12 foot wide boom
- The sprayer is traveling at 3 mph

48. Based on this information, calculate the flow rate in gallons per minute of the nozzle you should choose?

- GPA = 50
- MPH = 3
- Nozzle spacing = 18 inches

49. Using the handout on calibrating a hand sprayer, determine the area covered by a hand sprayer and an applicator with the following information.

Spray width = 18 inches (1.5 feet)
Traveled 60 feet in 15 seconds
Collected 12 fluid ounces in 15 seconds
Sprayer has a total capacity of 3 gallons

Based on this information, how many square feet covered will be covered by a full tank of spray solution?

_____ square feet

50. You wish to calibrate your drop spreader to seed some bermudagrass. You measure out a test area 50 ft long and you are using a drop spreader with a width of 36 inches. You wish to seed at a rate of 1.0 lbs/1000ft². You travel down 50 ft and back 50 ft once. How many grams of seed must you collect (down and back) in order for your spreader to be calibrated accurately?

51. You wish to calculate the sprayer portion of your ride-on spreader/sprayer. You travel an average of 19.74 seconds per 100 feet in low gear and collect 1350 mL of water in 30 seconds using the high volume output nozzle. Assuming that your effective spray width is 7 feet, how many gallons per acre would you be applying with this sprayer?

Additional fact sheets available at:
<http://publications.uaex.edu/>

For more information about turfgrass visit:
<http://turf.uark.edu/>

References

1. Anonymous. 2008. Irrigation Association: Advanced Head Layout & Zoning: Chapter 1. Uniformity and Efficiency. [Online] Available at: http://www.irrigation.org/edu/ahl/chapter_1.doc/. (Verified 16 April 2008).
2. Beard, J.B. 2002. Turf management for golf courses. Ann Arbor Press. Chelsea, MI.
3. Christians, N.C. and M.L. Agnew. 2008. The mathematics of turfgrass maintenance. John Wiley & Sons, Inc. Hoboken, NJ.
4. Reicher, Z. and C. Throssell. 2003. Sprayer and spreader calibration. Purdue University Course Notes.
5. Varner, D.L., R.D. Grisso, and R.C. Shearman. 1990. Calibration accuracy of golf course pesticide applicators. Applied Engineering in Agriculture. 6:405-411.

Acknowledgements

Special thanks to Drs. Mike Richardson, Doug Karcher, and John Boyd, as well as Mr. Jon Trappe for review of this publication and helpful suggestions during its development.

Disclaimer

The information given herein is for educational purposes only. Reference to commercial products or trade names is made with the understanding that no discrimination is intended and no endorsement by the University of Arkansas Cooperative Extension Service is implied.

Answers to Problems

46. 71.7 gallons per acre
47. 73.2 gallons per acre
48. 0.45 gallons per minute
49. 2,880 ft²
50. 136.2 grams
51. 14.6 GPA